

TEST EQUIP. POOL

Ⓜ MODEL 608C/D VHF SIGNAL GENERATORS

Ⓜ 608C Serials Below 247-04756

Ⓜ 608D Serials Below 247-08115

MODIFICATION FOR REGULATED DC FILAMENT OPERATION

This Service Note outlines the procedure for modifying the Ⓜ Model 608C/D VHF Signal Generators for regulated DC filament operation of the RF circuits.

The original multivibrator filament power supply in some cases caused ripple on the output RF signal from the generator. The DC filament supply prevents this from happening.

The modification consists of removing the multivibrator supply and installing the regulated DC power supply. The filament windings are then rewired to provide 12.6 VAC isolated from ground for driving the regulated DC filament supply.

No recalibration of the signal generator is required when the modification is completed.

PART FURNISHED IN MODIFICATION KIT
608C-95A OR 608D-95J

| Quantity | Description | Ⓜ Stock No. |
|----------|---|-------------|
| 1 | Capacitor, Fixed 1000 mf 25 vdcw | 0180-0057 |
| 1 | Plate, Transistor | 1200-0043 |
| 2 | Bushing, Transistor | 1200-0081 |
| 1 | Transistor | 1850-0087 |
| 1 | Bracket, capacitor | 608D-12R |
| 1 | Rectifier, Board Assembly | 608D-75H |
| | or | |
| | Rectifier, Board Assembly | 608C-75H |
| 1 | Socket, Lamp | 1450-0009 |
| 2 | Flat Washer, #4 | 3050-0016 |
| 1 | Terminal Lug | 0360-0016 |
| 2 | Machine Screw, Binding Head, w/Lockwasher, 6-32 x 3/8" | 2390-0009 |
| 2 | Machine Screw, 4-40 x 1/2 inch, Round Head | 2200-0009 |
| 2 | Nut, Hex, w/Lockwasher, 6-32 | 2420-0001 |
| 2 | Nut, Hex, 4-40 | 2260-0002 |
| 2 | Lockwasher, #4 | 2190-0004 |
| 1 | Gray Wire #22 Gauge, 90 inch length | 8150-0027 |

| Quantity | Description | Ⓜ Stock No. |
|----------|--|-------------|
| 1 | Brown Wire #22 Gauge, 90 inch length | 8150-0007 |
| 1 | Black Wire #22 Gauge, 4 inch length | 8150-0005 |
| 1 | Violet Wire #22 Gauge, 3 inch length | 8150-0030 |
| 1 | Brown Wire #18 Gauge, 25 inch length | 8150-0086 |
| 1 | Brown-Orange Wire #22 Gauge, 23 inch length | 8150-0009 |
| | (not required in 608C modification) | |

MODIFICATION PROCEDURE

NOTE

For 608C modification, substitute 608C-75H for 608D-75H. Delete step 28. In the following procedure, (NS) means do not solder connection. (S1) means solder connection. Number indicates number of wires on connection.

1. Disconnect power, remove cabinet cover.
2. Disconnect all wires on transformer T2. Remove T2, Attenuator Cable Shield, and T2 Mounting Bracket.

NOTE

If the mounting bracket is held on with PEM fasteners, it will be necessary to loosen the nuts supporting T1 so T1 can be tipped out of the way. This will allow removal of the screws holding the mounting bracket. It is not necessary to completely remove the nuts supporting T1.

3. Mount capacitor bracket 608D-12R where T2 bracket was located. Use 6-32 hardware. Tighten nuts holding T1.
4. Remove all leads from XV17. Use #27 drill to drill out rivets holding XV17. Remove socket.
5. Remove resistor board assembly 608D-75C and discard. Remove all red wires connected to R87 from instrument.

abcfjgp
01577-1



Customer Service • 395 Page Mill Road, Palo Alto, California 94306. Tel. (415) 326-3950



Europe: 54 Route Des Acacias, Geneva, Switzerland, Cable: "HEWPACKSA" Tel. (022) 42.81.50

6. Disconnect shielded cable and discard from FL-1.

NOTE

Refer to Figures 1 and 2 for the following wiring steps.

7. Mount transistor Q1, 1850-0087, at location of XV17. Slot one hole with a #27 drill to ease mounting of Q1. Make sure collector is not grounded.
8. Mount rectifier board assembly 608D-75H at location of 608D-75C.
9. Mount capacitor C75, 1000 mf, 25 vdc. Do not mount attenuator cable shield at this time.
10. Connect short white wire on 608D-75H to emitter of Q1 (S1).

11. Run long white wire on 608D-75H between 608D-75H and chassis, through hole for shielded filament cable. Connect to FL-1 (S1).

12. Run green wire on 608D-75H to base of Q1 (S1). Leave remaining wires on 608D-75H disconnected.

13. On transformer T1, remove connection from D5 to ground.

14. Connect a jumper from terminal C2 (S2) to terminal D1 (S3) on transformer T1.

15. Connect a brown wire #22, 24" length to terminal C1 on T1 (S2).

16. Connect a gray wire 24" length to terminal D2 on T1 (NS).

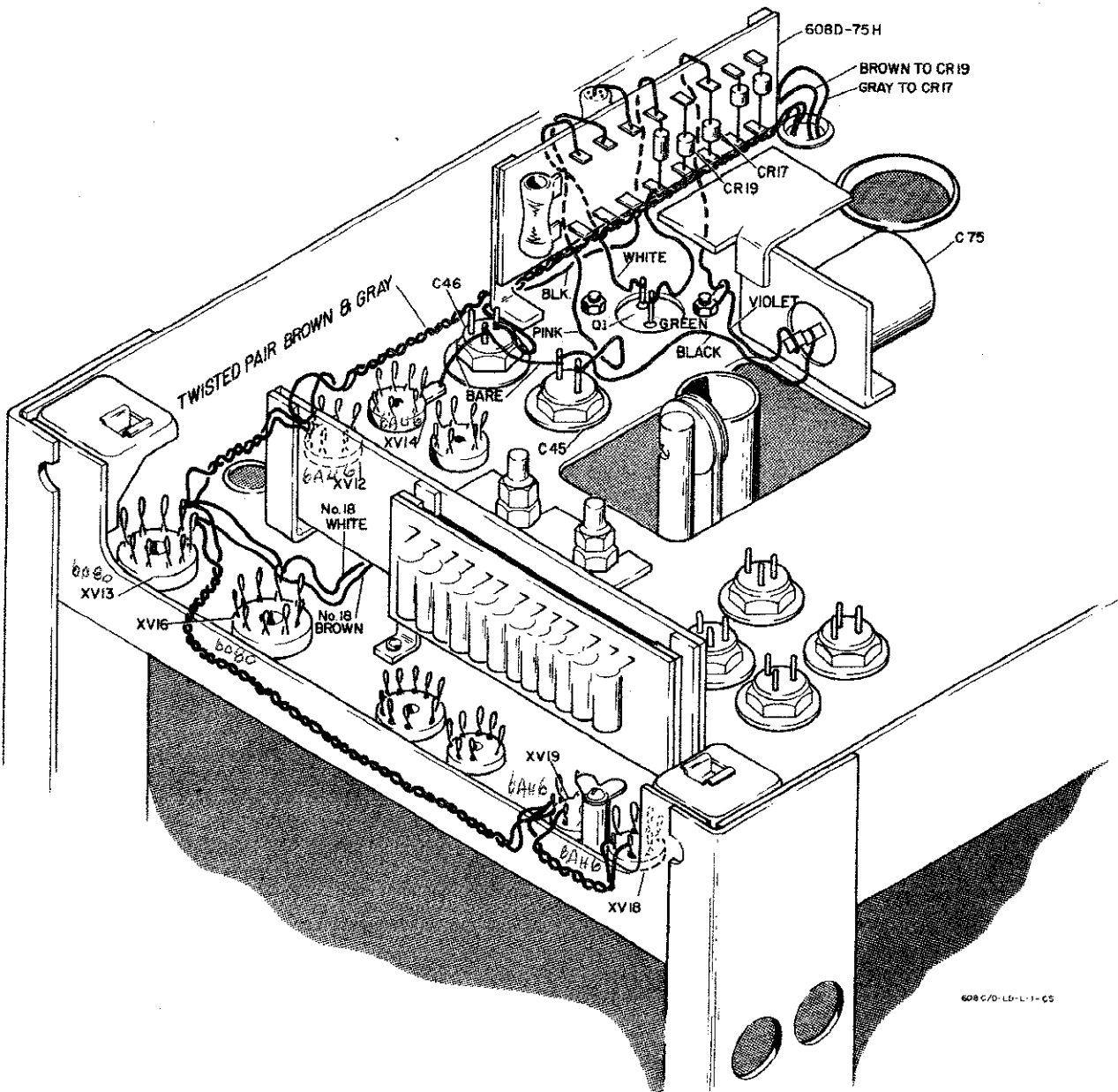

Figure 1. Model 608C/D DC Filament Installation

17. Run brown and gray wire from T1 through 3/4" hole at lower left of T1. Follow black and white wires to opposite side of chassis. Then run the brown and gray wires through the 1/2" hole in the lower right hand corner at the rear of the chassis. Follow cable harness. Run wires under 608D-75H. Connect gray wire to junction of CR-17 and CR-18 (S2). Connect brown wire to junction of CR-19 and CR-16 (S3).

18. Run pink wire on 608D-75H between 608D-75H and chassis. Connect to negative side of C45 (S3).

19. Rotate C46 so red terminals are vertical and nearest to chassis edge. Connect negative on C46 (NS) to ground lug on XV14 (S1).

20. Run black wire on 608D-75H between 608D-75H and chassis. Connect to negative on C46 (S3).

21. Connect black wire 4" length from positive of C75 (S1) to grounded side of C45(S2).

22. Connect a violet wire, 3" length to negative side of C75 (S1).

23. Run violet wire on 608D-75H between 608D-75H and chassis. Connect violet wire from 608D-75H and violet wire on C75 to collector terminal lug on Q1 (S2). Replace attenuator shield.

24. Remove ground connections from pin 3 of XV12, XV14, XV18, and XV19, and from pin 8 of XV13 and XV16. Disconnect white wire #22, from pin 4 of XV18, XV19, XV12, and XV14. Remove from instrument.

25. Disconnect black wire from pin 8 of XV16 and connect to ground lug on XV16 (S1).

26. Connect brown wire #18, 25" length, to terminal D2 of T1 (S3). Follow white lead on terminal D1 of T1 up to tube socket XV16. Connect brown wire to pin 8 of XV16 (NS).

27. Disconnect and discard #22 white wires from pin 7 of XV13.

28. Connect brown-orange wire 23" length to terminal C4 on T1 (S3). Run wire through 3/4" hole at lower left of T1, across to other side of chassis, and up to FL4 (S1).

29. Connect brown wire #18, 3" length, between pin 8 of XV16 (S2) and pin 8 of XV13 (NS).

30. Make a length of twisted pair 56" long. Use #22 gray wire and #22 brown wire.

NOTE

In following instructions, connect brown wire to pin 3 and gray wire to pin 4. On XV13 connect gray wire to pin 7, brown wire to pin 8. Use lengths of twisted pair as indicated.

01577-1

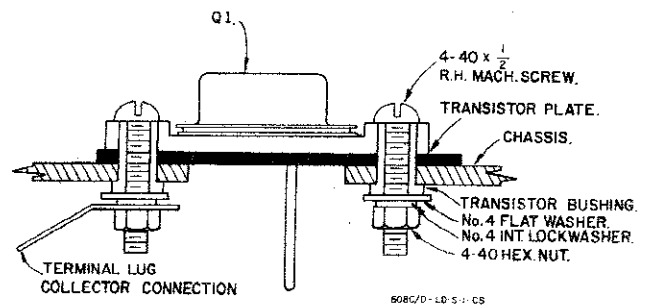

Figure 2. Transistor Q1 Mounting

31. Connect a 3" length from pins 3 and 4 of XV18 (S1) to pins 3 and 4 of XV19 (NS).

32. Connect an 8" length from pins 3 and 4 of XV19 (S2) to pins 7 and 8 of XV13 (NS).

33. Connect a 4" length from pins 7 and 8 of XV13 (S3) to pins 3 and 4 of XV12 (NS).

34. Connect a 3" length from pins 3 and 4 of XV12 (S2) to pins 3 and 4 of XV14 (NS).

35. Connect a 30" length of twisted pair to pins 3 and 4 of XV14 (S2). Follow cable harness down toward bottom right hand corner of chassis through 1/2" hole toward front panel.

36. Remove all wires presently connected to power lamp socket, XI4, from instrument.

37. Connect twisted pair to XI4 (NS).

38. Remove Frequency Dial knob. Remove and discard dial illuminating lamp socket XI3.

39. Connect an 8" length of twisted pair to the terminals of lamp socket part 1450-0009 (S1) on each terminal. Mount socket in place of XI3. Replace Frequency Dial knob.

40. Run twisted pair on XI3 over to XI4 and connect (S2) on each terminal of XI4.

41. This completes the rewiring. Check wiring for accuracy.

42. Turn the signal generator on measure voltage at outside of FL-1, should be 6.8 vdc for Model 608D; 6.5 for Model 608C. If necessary, pad R128 with a two watt resistor to bring the voltage within tolerance.

43. This completes the modification. Turn power off. Replace instrument cabinet.

The attached partial schematic, Figure 3, should be added to your Operating and Service Manual for future reference.

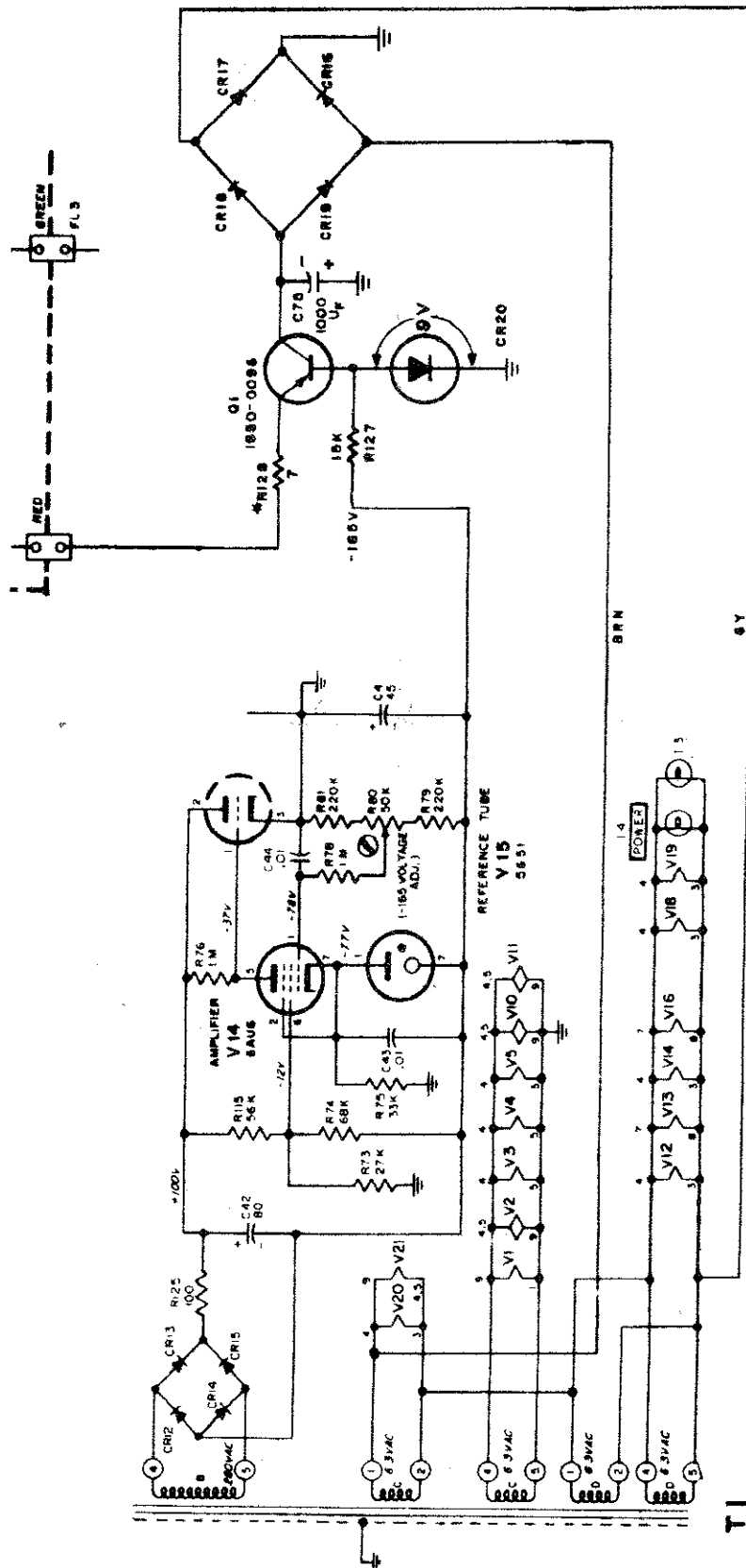

Figure 3. Model 608C/D VHF Signal Generator

S E R V I C E N O T E

SUPERSEDES:

P-608A-34 (Rev. 2/69)

HP PART NUMBER 608A-34, 608D-34, 608D-34S, AND 00608-610 REPLACEMENT ATTENUATOR ASSEMBLY

This Service Note contains information necessary for replacing and recalibrating the output attenuator in the 608A/B/C/D/E/F Signal Generators. The procedure is described for each model, using the appropriate replacement attenuator.

EQUIPMENT REQUIRED

A microwave power meter and thermistor mount such as HP Model 432A, 478A combination will be required for calibration.

NOTE

Should it be necessary to replace the drive cable, a new drive cable and drive screw assembly is available under HP Part No. 5060-0205.

DESCRIPTION

The RF power output from the power amplifier is obtained from the resonant plate circuit by means of a pickup loop located in a section of circular

waveguide which opens adjacent to the resonant circuit. The waveguide is smaller than the cut-off size of waveguide designed for use at the frequencies generated by the Model 608 and the energy propagation decreases linearly in dB down the waveguide.

A pulley drive system moves the pickup loop in the waveguide. The energy coupled into the output system varies with the position of the pickup loop.

The attenuator dial is calibrated directly in dB below 1 milliwatt into 50 ohms. A second scale on the attenuator dial is calibrated directly in millivolts and microvolts output across a 50 ohm resistive load.

The pickup loop couples energy from the resonant circuit to the output connector through a special matching network. This network consists of two resistors and a small variable capacitor. The setting of this capacitor primarily determines the standing wave ratio at the instrument output terminals. Do not disturb the factory setting of this capacitor or the position of other components on the end of a replacement attenuator.

JD/mh/wo

6/69-4

HEWLETT  PACKARD

NOTE

Since 1956 HP attenuator probes have included a capacitor (C69) in the probe to block ground loop currents between the probe ground and the front panel ground. See 608C/D Probe Schematic. This eliminates spurious signals which could appear at the signal generator output. C69 is a .01 μ F 400 volt Mylar capacitor. It was added to the circuit in series between the probe pickup loop and the probe body which is ground. Because of this capacitor, a dc resistance check of the probe between the center conductor of the jack and ground will indicate an open circuit which is normal. A VHF impedance bridge such as the HP 803A may be used to verify impedance of the probe assembly.

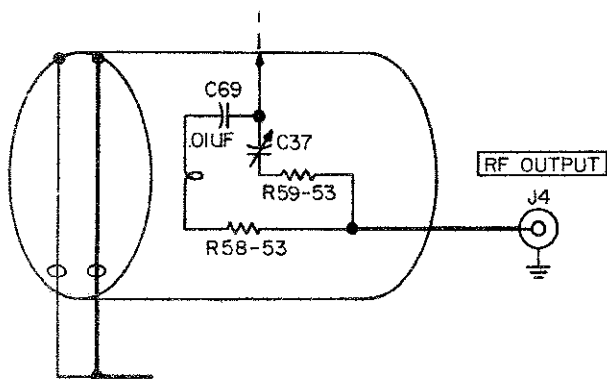

Probe Schematic (608C/D)

If excessive power is accidentally applied to the attenuator circuit from an external source, the precision resistors on the output attenuator will be damaged and in most cases burned out. Fuseholder HP Part No. 11509A is available as an accessory to prevent output attenuator damage.

REPLACEMENT PROCEDURE

1. Remove cabinet.
2. Release or Remove Drive Cable from Attenuator:
 - a. If drive screw (1) is slotted, remove nut and pin; slide cable (2) out of slot.
 - b. If drive screw (1) is not slotted, or if cable (2) is frayed, cut cable (2), remove, and discard.

NOTE

Before removing drive cable, note routing of cable and compare with step 5. This will make drive cable replacement easier.

3. Remove Attenuator:

- a. Completely remove attenuator drive screw (1) by unscrewing from attenuator. (First remove lock nut from end inside tube.)

- b. Pull attenuator out of attenuator tube (3). (Waveguide.)

- c. Release attenuator output cable (4) from chassis by removing clamp.

- d. Unscrew knurled sleeve on rear of front panel output connector.

- e. Pull output connector back from panel and then out through hole in rear of chassis. Cut out or remove rubber grommet (608A/B only). A new grommet is supplied on the new attenuator cable.

4. Install Attenuator in Tube (3):

- a. Check attenuator fingers (8). They should project 1/6" to 1/32" past side of attenuator. (If too tight, attenuator will not move freely. If too loose, will cause RF leakage.) Adjust if necessary. If necessary, the fingers can be burnished for smoother operation.

- b. Line up drive screw hole with slot (5) in tube (3).

- c. Compress fingers and insert attenuator into tube.

- d. Install drive screw, using new slotted type. This makes future replacement easier.

- e. Make sure fingers do not catch at forward end of drive screw slot. Bend a finger in toward attenuator as necessary.

- f. Align drive screw, drive screw slot, and rear pulley (9) so cable will run straight.

- g. Pass connector through chassis and replace on panel.

- h. Secure cable clamp, forming cable toward corner near 1/16 Amp. fuse. If this is not done, cable will hit back of case and prevent proper operation.

5. Replace Drive Cable if Necessary:

- a. Turn attenuator dial to extreme counterclockwise position.

- b. Face right rear corner of instrument.

- c. Pass end of drive cable through top hole (11) in drive pulley (12) and secure end under screw (14).

- d. Pass free end up over pulley, around upper idler pulley (15) through slot in drive screw (1), around rear idler pulley (9), around lower idler pulley (16), and out the side under the drive pulley.

NOTE

For the following three steps obtain help, or secure the drive pulley to the stop (with wire or string) in the clockwise position.

e. Keeping the tension on cable, turn attenuator to extreme clockwise position. This winds up one turn on drive pulley.

f. Pass free end under drive pulley and into hole (17).

g. Secure end of drive cable under screw (18), keeping cable taut.

6. Replace Drive Cable in Slot, and Adjust for Optimum Tension:

a. Loosen Allen screw in rear pulley (9) assembly.

b. Pull back on pulley to get desired tension. (If the cable is too tight, the attenuator will not move freely. If too loose, there will be backlash).

c. Tighten Allen screw.

7. Secure Drive Cable to Attenuator:

a. Set attenuator dial at extreme clockwise position.

b. Remove side cover plate and gasket from generator casting.

c. Lift drive cable out of slot and thread one 10-32 hex nut on the attenuator drive screw.

d. Place one fiber washer over the attenuator drive screw and then insert drive cable in the drive screw slot.

e. Plate the remaining fiber washer over drive screw followed by the second 10-32 hex nut. Position the two nuts so that when they are tightened later the cable will be clamped between the two fiber washers in a straight line between pulleys 9 and 15.

f. Slide attenuator forward until the pickup loop (19) is flush with inner end of tube.

g. Tighten nuts on attenuator drive screw.

h. Make sure that these nuts do not hit rear pulley assembly in counterclockwise position of the attenuator control.

i. Check pickup loop position with attenuator control full clockwise. Loop should be flush with inner end of tube.

j. Check amplifier turret and coils. They must not touch the pickup loop when the range switch is operated.

8. 608A/B Attenuator: (Calibration for Models 608C/D refer to appropriate Operating and Service Manual.)

a. Turn attenuator dial to extreme clockwise position.

b. Make sure dial reads exactly +7 dB. If not, loosen attenuator dial knob and reset.

c. Turn dial to indicate exactly -1 dB.

d. Apply power to instrument.

e. Connect bolometer mount and power meter to the Model 608.

f. Set Model 608 to 10 MHz and peak trimmer.

g. Set output level control until external power meter indicates exactly -1 dB.

h. Adjust R20 potentiometer on bracket at rear of generator casting, so that output meter on Model 608 indicates exactly 0.5 volts.

i. Check all bands for correct power output.

j. Reset attenuator dial to +7 dB and adjust output to Set Level.

k. Check all bands for correct power output. Measured output should be +7 dB plus or minus 1 dB.

m. Readjust R20 if necessary to compromise for errors noted in these measurements.

NOTE

Errors at the -1 dB level should be kept as small as possible since the accuracy of this setting determines the accuracy at lower attenuator settings. The attenuator is very linear below 0 dB but due to endfringe effects of the attenuator tube, there is some non-linearity above 0 dB.

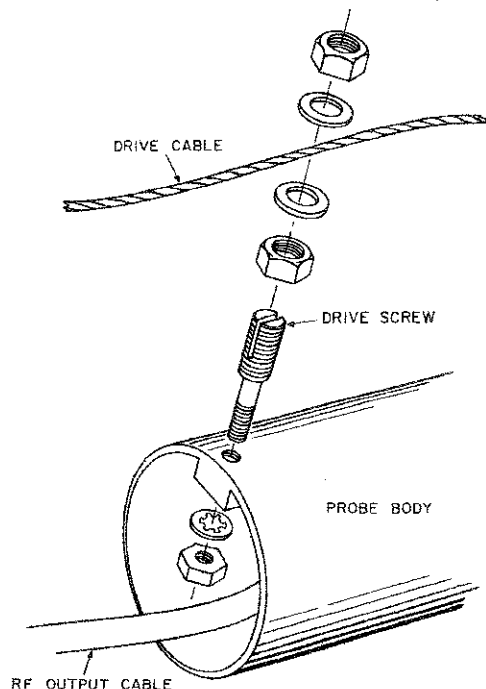

Drive Cable Clamp

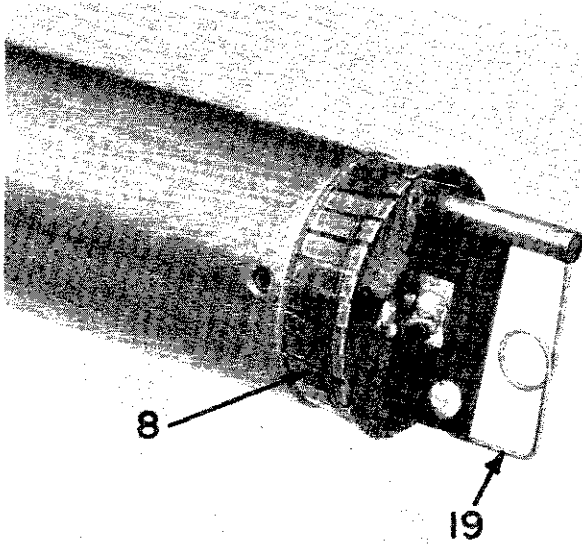

End View
Old Style Attenuator

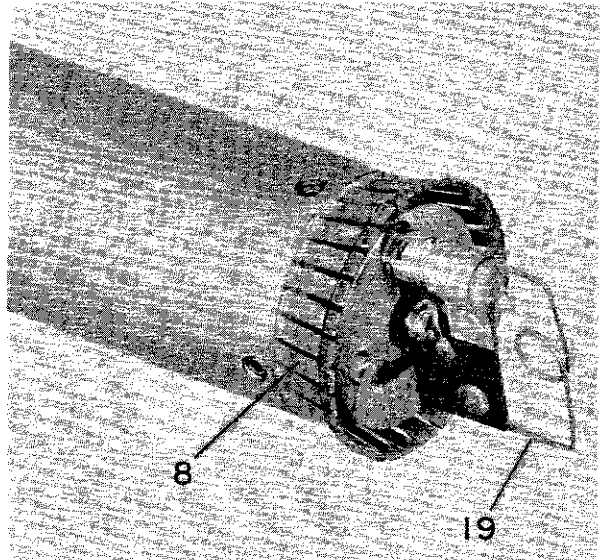

End View
New Style Attenuator

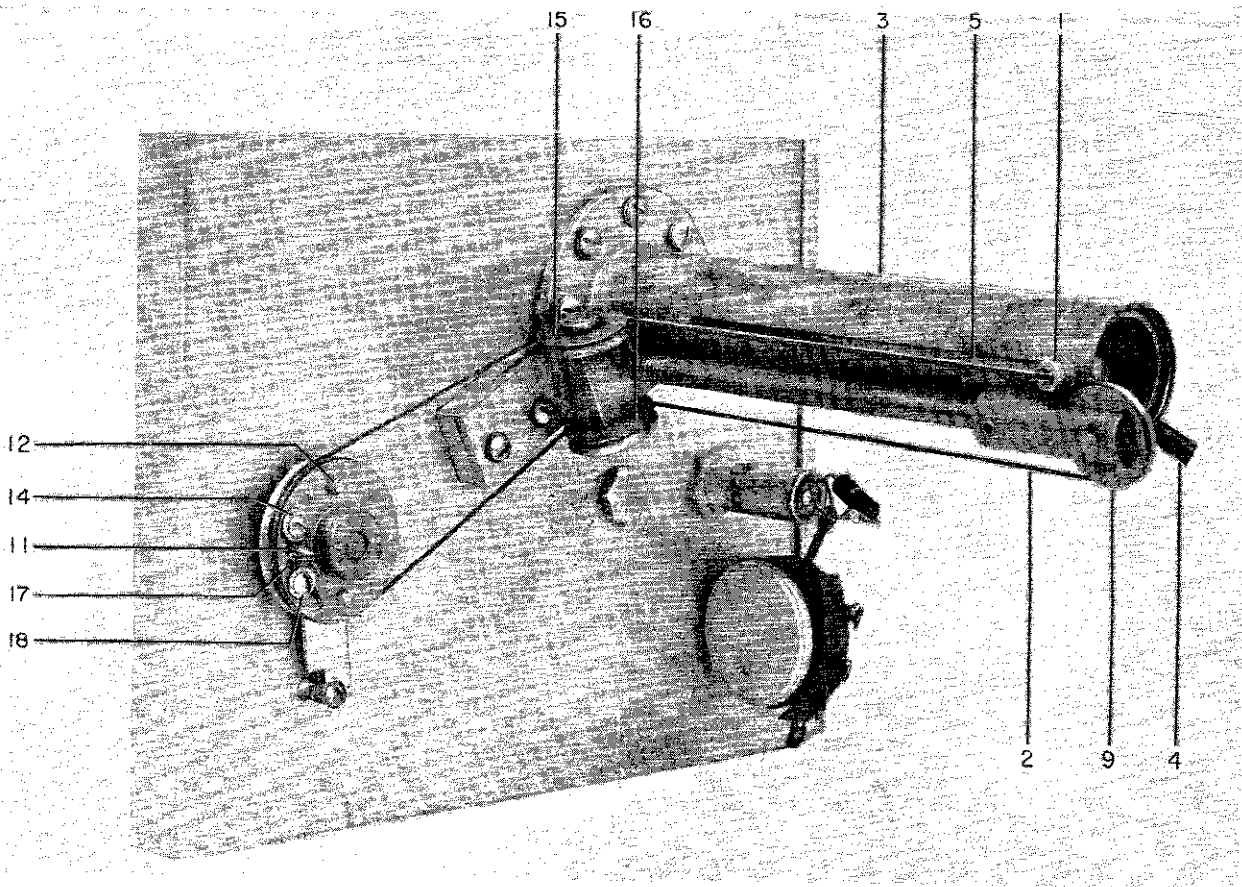

Generator Casting, Attenuator Tube and Drive Mechanism

hp MANUAL CHANGES

MODEL 608C

VHF SIGNAL GENERATOR

Manual Serial Prefixed 326-
Manual Printed 8/63

To adapt this manual to instruments with other serial prefixes check for errata below, and make changes shown in tables.

| Instrument Serial Prefix | Make Manual Changes | Instrument Serial Prefix | Make Manual Changes |
|--------------------------|---------------------|--------------------------|---------------------|
| 310-05018 to 05209 | 1 | | |
| 247-04756 to 05017 | 1, 2 | | |
| | | | |
| | | | |

CHANGE 1

AT1,  Stock No. 608D-34. The attenuator probe assembly shown below is identical to the one shown in Figure 4-8a except that the SETSCREW for C37 is located as shown and may be adjusted for minimum VSWR if positioning resistors R59 and R58 does not do the job.

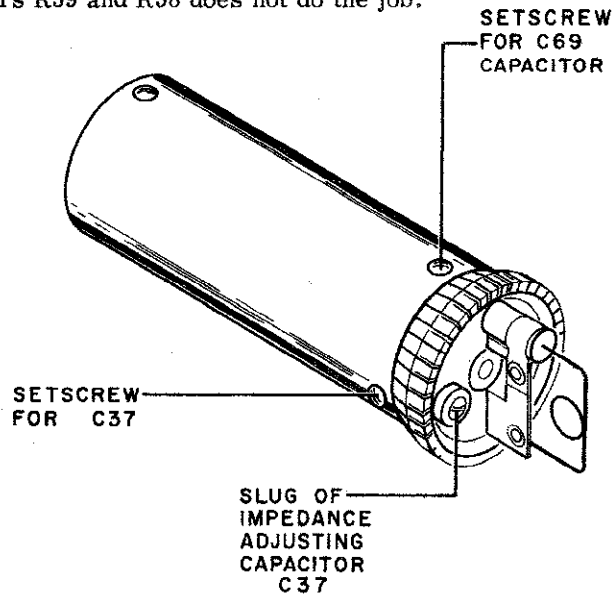

CHANGE 2

Table of Replaceable Parts and Figure 4-17.

Q1: Change to  Stock No. 1850-0098; Transistor, PNP, germanium, Mfr 98925, Mfr Part No. CQT-794 (alternately: Mfr 83298, Mfr Part No. B-1493).

10/3/63

Supplement B for
608C-901

hp MANUAL CHANGES

MODEL 608C

VHF SIGNAL GENERATOR

Manual Serial Prefixed: 010-
Manual Printed: 1-61

To adapt this manual to instruments with other serial prefixes check for errata below, and make changes shown in tables.

| Instrument Serial Prefix | Make | Manual | REGIONAL HEADQUARTERS DRAWING | Instrument Serial Prefix | Make | Manual Changes |
|--------------------------|------|--------|-------------------------------|--------------------------|------|----------------|
| 202- | 1 | | RADIO | MAINTENANCE | | |
| All | 2 | | | | | |
| | | | NOT TO BE REMOVED | | | |
| | | | | | | |

- CHANGE 1
- I1: Change to lamp, incandescent: 250V, 10W; Ⓟ Stock No. 2140-0007; Mfr. 24455.
 - R8: Change to resistor, fixed, composition, 680 ohms $\pm 10\%$, 1W; Ⓟ Stock No. 0690-6811; Mfr. 01121.

- CHANGE 2
- V6: Tube, electron; Ⓟ Stock No. 1921-0001 may be marked 5675, H.P.4042, or 1921-0001.
 - V8: Tube, electron; Ⓟ Stock No. 1921-0002 may be marked 5876, H.P.4043, or 1921-0002.

ERRATA:

Table of Specifications,
Modulation Meter Accuracy should read: $\pm 10\%$ of full scale, 30% to 95% modulation.

Table of Replaceable Parts, under MISCELLANEOUS:
Fuseholder: Change Ⓟ Stock No. to 1400-0084.

Table of Replaceable Parts,

R60: Change to resistor, fixed, composition, 120 ohms $\pm 10\%$, 1/4W;
Ⓟ Stock No. 0684-1211; Mfr. 01121.

R108, Change to resistor, fixed, composition, 27 ohms $\pm 10\%$, 1/4W;
112: Ⓟ Stock No. 0684-2701; Mfr. 01121.

R109: Change to resistor, fixed, composition, 100 ohms $\pm 10\%$, 1/4W;
Ⓟ Stock No. 0684-1011; Mfr. 01121.

R110, Change to resistor, fixed, composition, 47 ohms $\pm 10\%$, 1/4W;
115: Ⓟ Stock No. 0684-4701; Mfr. 01121.

R111, Change to resistor, fixed, composition, 150 ohms $\pm 10\%$, 1/4W;
113: Ⓟ Stock No. 0684-1511; Mfr. 01121.